

EXACTECH | HIP

Operative Technique



ALTEON[®]

Monobloc Revision Femoral Stem
Revision Femoral Solutions





TABLE OF CONTENTS

OBJECTIVES.....	1
DESIGN TEAM.....	1
ASSESSMENT OF BONE LOSS	2
CLASSIFICATION	2
EVALUATION	2
IDENTIFICATION OF FEMORAL REMODELING.....	3
PRE-OPERATIVE PLANNING	4
TOOLS	4
ESTABLISHMENT OF REFERENCE POINTS.....	4
DETERMINATION OF LEG LENGTH	4
IMPLANT PLACEMENT	4
FEMORAL REAMING PHILOSOPHIES	5
METHOD 1.....	5
METHOD 2.....	5
OPERATIVE TECHNIQUE OVERVIEW.....	6
DETAILED OPERATIVE TECHNIQUE	8
APPROACH AND PATIENT POSITIONING.....	8
COMPONENT REMOVAL	8
OPENING OF THE FEMORAL CANAL (IF NECESSARY).....	9
FEMORAL CANAL PREPARATION.....	10
Tapered Reaming	10
Trochanteric Reaming	11
STEM TRIAL INSERTION	13
TRIAL REDUCTION	15
TRIAL COMPONENT REMOVAL	17
FINAL FEMORAL STEM PLACEMENT	17
Final Stem Insertion	17
Femoral Head Impaction	19
FINAL REDUCTION.....	19
Implant Removal	19
CLOSURE.....	19
SYSTEM SPECIFICATIONS.....	20
IMPLANT ORDERING INFORMATION	21
INDICATIONS FOR USE.....	21
TRAY LAYOUT	22

OBJECTIVES

The goal of the surgical approach is to establish adequate exposure to assess bone loss and restore leg length, stability and kinematic function. There are a variety of surgical approaches that can be used, depending upon surgeon experience and preference. This technique provides key surgical steps to implant the Alteon® Monobloc Revision Femoral Stem. For key surgical steps specific to the acetabulum, refer to the appropriate acetabular technique.

Goals of Revision Hip Arthroplasty:

- Assess bone loss and select components to achieve stability
- Restore kinematics with correct leg length and offset
- Assess acetabulum and its influence on femoral components

DESIGN TEAM

ANDREW GLASSMAN, MD, is Professor and Chairman of the Department of Orthopaedics and Chief of the Division of Adult Reconstructive Surgery at Ohio State University Wexner Medical Center in Columbus, Ohio. He attended medical school at the Medical College of Ohio, and completed his orthopaedic surgery residency at the Ohio State University; and a fellowship in Adult Reconstructive Surgery at the Anderson Clinic and the National Hospital for Orthopaedics and Rehabilitation in Arlington, Virg.

MICHAEL KANG, MD, practices at the Insall Scott Kelly Institute for Orthopaedics and Sports Medicine in New York, N.Y. He is also Clinical Assistant Professor at NYU School of Medicine. After completing his medical education from Temple University, he received his training in orthopaedic surgery at the New Jersey Medical School. He proceeded to a fellowship in Adult Reconstruction of the Hip and Knee at Stanford University.

JEFF PIERSON, MD, practices with Franciscan St. Francis Health in Carmel, Ind. He attended The Johns Hopkins University School of Medicine in Baltimore; his general surgery internship at Northwestern University Medical Center, Chicago; and his orthopaedic residency at the Hospital for Special Surgery. He completed his orthopaedic fellowship in adult hip and knee reconstruction at Harvard University.

JOSE RODRIGUEZ, MD, is the Chief of Reconstruction Arthroplasty and the Director of Arthroplasty Fellowship Program at Lenox Hill Hospital in New York, N.Y. Dr. Rodriguez completed his medical school education at Columbia University College of Physicians and Surgeons, and his residency training at the Hospital for Special Surgery. He completed two fellowship programs—one at Lenox Hill Hospital for arthritis surgery and joint reconstruction and the other was the Maurice E. Müller Foundation Fellowship in Hip Surgery at University of Berne, Switzerland for the surgical treatment of fractures.

ASSESSMENT OF BONE LOSS

CLASSIFICATION

When undertaking revision total hip replacement, an accurate pre-operative assessment of existing bone stock damage is important for several reasons. Firstly, the surgeon must assess the quality, location and shape of the bone which remains available for fixation of revision components. This is an essential first step to pre-operative planning in terms of the operative approach, implants, bone graft and special instrumentation required. Secondly, the use of a recognized classification system facilitates communication, allowing surgeons to confer with one another regarding treatment for individual patients. Finally, meaningful comparison of the various revision techniques currently in use is impossible unless they have been applied to cases with comparable degrees of bone stock damage. Only then is it possible to know which implants and techniques are best for any given situation.

We recommend the simple but utilitarian system for classifying femoral bone stock damage described by Paprosky and associates which is illustrated below (*Figures 1-4*).¹ The majority of cases exhibiting Type I, Type II and Type III-A bone stock damage can be managed with a monobloc, tapered, splined stem. Type III-B cases are generally managed with modular, tapered revision stems. Type IV cases are, in general, managed with alternative strategies, including impaction grafting, allograft-prosthetic composites, tumor megaprotheses or total femoral replacement.

EVALUATION

Plain film evaluation of the hip is generally sufficient for an accurate assessment of bone stock damage. The minimum views include an anterior/posterior (A/P) pelvic view, and A/P and lateral views of the femur. In cases of advanced acetabular bone stock damage, Judet views are helpful. With few exceptions, we have not found CT scans necessary.

Achieving initial mechanical stability of the Alteon Monobloc Revision Stem, and subsequent osseointegration, is critically dependent upon the extent and quality of host bone contact that is achieved. Careful assessment of pre-operative radiographs in order to identify the available host bone is a necessary first step. Radiographs are examined for cortical defects and angular deformities, using bi-planar radiographs. In addition, the possible need for extensile approaches such as an extended trochanteric osteotomy (ETO) are ideally planned in advance. In this way one can optimize osteotomy positioning for implant extraction, deformity correction, and revision stem placement. Intra-operative assessment, possibly including radiographic imaging, is used to confirm the pre-operative assessment of bone loss and surgical plan.

Figure 1



In Type I, or mild bone stock damage, the cortices of both the metaphysis and isthmus remain intact. Unless the cortical tube is completely devoid of cancellous bone, the situation closely resembles that encountered during primary arthroplasty, and can be treated as such, using the fixation method with which the surgeon is most confident.

Figure 2



In Type II, or moderate bone stock damage, the metaphysis is significantly compromised, yet the isthmus remains intact. In the majority of published reports, Type II bone stock damage is the most commonly encountered. When the metaphysis is significantly damaged, proximally porous-coated stems cannot be relied upon to provide for long-term fixation by bone ingrowth.

Figure 3



In Type III (severe) bone stock damage, both the metaphysis and the isthmus are damaged. Type III cases can be further categorized:

- Type III-A: Those with four or more centimeters of remaining structurally sound bone in the isthmus.
- Type III-B: Those with less than four centimeters of remaining bone.

Figure 4



In Type IV bone stock damage the isthmus has been functionally obliterated.

1. Della Valle CJ, Paprosky WG: The Femur in Revision Total Hip Arthroplasty Evaluation and Classification. Clin Orthop Relat Res. 2004 Mar;(420):55-62.



Figure 5



Figure 6

IDENTIFICATION OF FEMORAL REMODELING

Proper pilot hole placement is critical to subsequent preparation of the femoral canal. Loose femoral components typically (but not always) shift into varus and retroversion (*Figures 5 and 6*). Overgrowth of the greater trochanter may obscure the optimum axial entry point for initiation of femoral preparation (*Figure 7*).

Any trochanteric overhang obscuring the femoral canal should be relieved and the pilot hole lateralized in order to avoid varus positioning of the revision stem or lateral cortical perforation (*Figure 7*). A high-speed burr is the preferred instrument (*Figure 8*).

The femoral component frequently shifts in the sagittal plane as well. Consequently, the proximal aspect of the stem typically migrates posteriorly (*Figure 9*). As such, the pilot hole should be adjusted far enough anteriorly to allow one to navigate the anterior bow of the femur (*Figure 10*).

Varus remodeling of the femoral shaft may lead to proximal-distal femoral conflict (*Figures 11 and 12*). Unlike simple trochanteric overhang, varus remodeling of the femoral shaft cannot be corrected by lateralizing the pilot hole and may require a corrective subtrochanteric osteotomy (*Figures 13 and 14*).



Figure 7



Figure 8



Figure 11



Figure 12

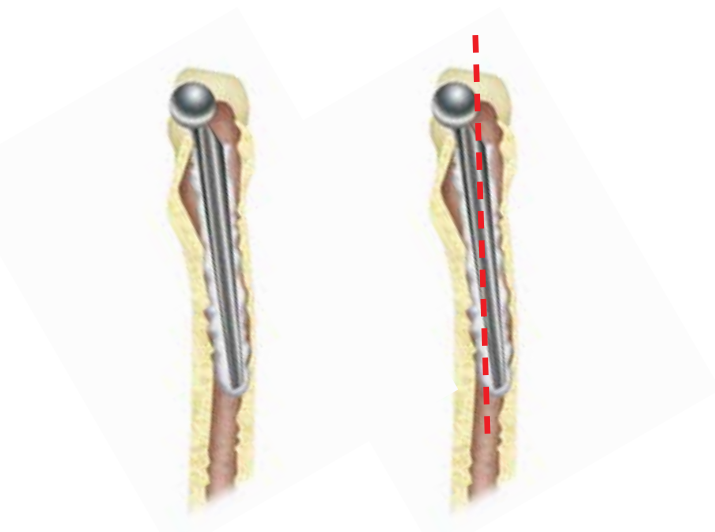

Figure 9

Figure 10



Figure 13



Figure 14

ALTEON® MONOBLOC REVISION STEM

PRE-OPERATIVE PLANNING

Templating is recommended to determine the intraosseous features of the host bone, as well as the extraosseous features including leg length and offset. One can then identify bony reference points that can be utilized intra-operatively to assist in the restoration of normal hip biomechanics.

TOOLS

- A/P pelvic view radiograph centered on the pubic symphysis
- A/P and lateral radiographs of the femur
- **Monobloc Revision Femoral Stem Template Set** with 120 percent magnification rule

Traditional templating methods may be used. For an estimated determination of required offset, vertical limb length and stem size, the following detailed templating method may be used to help guide the surgeon in selecting a final implant choice.

ESTABLISHMENT OF REFERENCE POINTS

Note: The standard templates only include the 195mm and 245mm lengths, however digital versions are available which include all lengths if necessary.

On the A/P pelvic view radiograph, a straight line is drawn across the bottom of the pelvis touching both ischial tuberosities equally. The line is extended far enough to reach each lesser trochanter. Such a line should be perpendicular to the vertically oriented pubic symphysis. If the line is not vertically oriented, it should be confirmed that the patient's pelvis was not tilted when the radiograph was taken. If the ischial tuberosities are poorly defined, the line should be drawn through the inferior portion of both obturator foramina or the inferior aspect of both teardrops.

DETERMINATION OF LEG LENGTH

Soft tissue tension around the hip joint can be considered in a simplified form to have a vertical and horizontal component. The position of the reference line with respect to each lesser trochanter is used to determine the pre-operative leg length, and based on clinical leg length assessment, to plan the desired change in the vertical soft tissue tension by way of leg length adjustment. Additionally, the offset of the current femoral component is examined, and a decision is made on whether to alter the horizontal component of soft tissue tension in order to optimize stability and muscle tensioning. In this way an optimal position for the femoral head center of rotation (COR) of the new reconstruction is developed and marked on the radiograph. Additional measurements can be made from other anatomical landmarks (i.e., cables, trochanteric flare and planned osteotomy site) to the COR for secondary checks on implant placement.

Note: The **Tapered Reamers** are marked with a groove corresponding to the vertical location of a +0 femoral head

COR with respect to the distal taper of the 195mm, 245mm, and 295mm long stems. The **Tapered Reamer Referencing Guide** provides the surgeon with a reference for other features of the stem, such as the lateral shoulder and the medial or lateral spline starting points. Using the digital software or pre-cut template marks, measurements may be made on the radiograph and recorded in the pre-operative plan. This allows the surgeon to reference back to the anatomical landmarks at the time tapered reaming is being performed.

IMPLANT PLACEMENT

Once the desired COR is chosen, one must decide where the optimal osseous support for implant placement exists to provide sufficient resistance to vertical, angular and rotational forces. In the majority of femoral revisions (Paprosky Type II and III-A Bone Defects), the position within the proximal to mid-isthmus provides excellent bone for reconstruction. The length and diameter of the implant are determined by connecting the desired COR with the desired diaphyseal cortical engagement.

Note: The Monobloc Revision Femoral Stem Template Set represents the available femoral head options. It is recommended that templating is not performed with the shortest head (-3.5mm), but rather something in the middle of the range.

The extent of diaphyseal engagement is often not easy to predict. Longer implants will be tapering in a manner opposite to the femur distal to the isthmus. In addition, longer lengths may create a conflict with the femoral bow, or the acquired angular deformity of the femur. Although 4cm of cortical engagement is desirable, occasionally as little as 2cm of solid cortical engagement is all that can be achieved. In cases of greater complexity, the use of intra-operative fluoroscopy can be quite useful to guide reaming, osteotomy positioning and implant placement.

Note: The Monobloc Revision Femoral Stem is intended to achieve fixation in the distally-tapered region of the stem, however, adjunctive proximal support is recommended when bone stock is available.

The Monobloc Revision Stems are designed such that the outer profile of the splines engage the cortices and thus, during pre-operative planning the outer profile of the stem's splines should be at least as wide as the femoral canal.

When an ETO is planned, the tapered portion of the implant should ideally extend at least 4cm beyond the most distal aspect of the osteotomy site.

Once the stem which best addresses the previously described considerations has been identified, the implant size, length, head offset, leg length adjustment and osteotomy (if

necessary) are recorded. The final COR to secondary landmark measurements are also completed and recorded for intra-operative reference.

Note: For digital templating, follow the software manufacturer's instructions for use while following the preceding instructions regarding placement and implant fit.

Note: Templating is an important part of pre-operative preparation, and should only serve as a guide. Final decisions concerning fit, size and soft-tissue tensioning occur in the operating room using available options of stem offset, head offset and liner configuration.

FEMORAL REAMING PHILOSOPHIES

Several distal femoral preparation philosophies co-exist amongst surgeons based on prior training and personal preference. Two suggested techniques will be outlined here, both of which have the same end goal of creating a stable final implant.

Note: The Tapered Reamers are marked with a groove corresponding to the vertical location of a +0 femoral head COR with respect to the distal taper of the 195mm, 245mm, and 295mm long stems (Figure 15). As necessary, the Tapered Reamer Referencing Guide may be snapped onto the Tapered Reamer and used to mark the femur at locations distal to the COR that will correspond to features of the **Stem Trial** and Final Prosthesis (Figure 16).

METHOD 1

Ream by hand advancing each reamer until axial and rotational stability are achieved. In most cases, this occurs when it is difficult to manually advance the Tapered Reamer distally. Assess the location of the groove marked on the Tapered Reamer to the landmark(s) and planned COR identified during templating (see close up on Figure 15). Choose the stem length and continue tapered reaming. Increase the reamer

diameter until axial and rotational stability are achieved with the Tapered Reamer groove (of the chosen stem length) aligned with the desired COR and/or corresponding landmarks.

Potential advantages:

- possibly easier to teach
- no/minimal need for intra-operative fluoroscopy

Potential disadvantages:

- has more opportunity for three-point fixation and relies slightly less on a strict taper philosophy
- results in the use of longer stems in a certain percentage of cases

METHOD 2

Ream by hand advancing each Tapered Reamer until the groove marked on the reamer (corresponding to the desired stem length) aligns with the landmarks and planned COR identified during templating (see close up on Figure 15). Smaller sizes may not achieve axial and rotational stability when tapered reaming. Increase the Tapered Reamer diameter until axial and rotational stability are achieved at the templated stem length and desired COR.

Potential advantages:

- relies less on three-point fixation and more on a strict taper philosophy
- results in a shorter stem in a certain percentage of cases

Potential disadvantages:

- pre-operative templating accuracy may be more important
- generally requires more intra-operative fluoroscopy

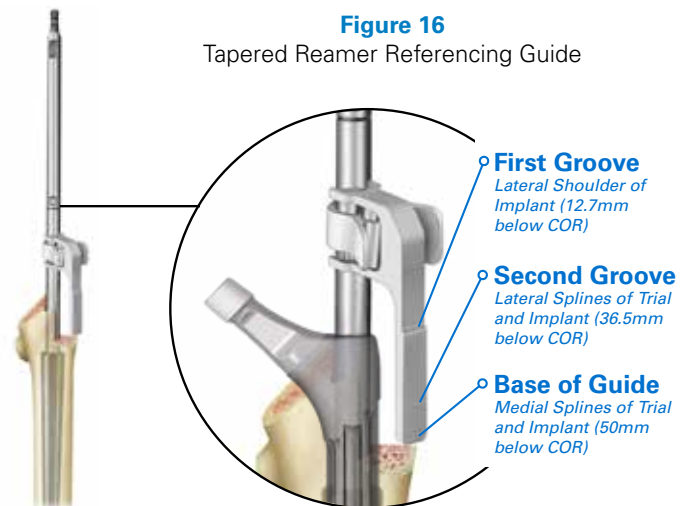
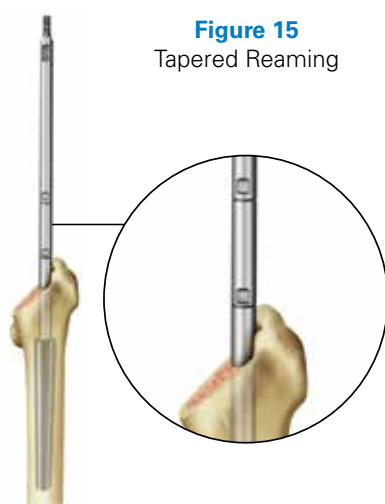

OPERATIVE TECHNIQUE OVERVIEW



Figure A
Tapered Reaming



Figure B
Tapered Reamer
Referencing Guide



Figure C
Trochanteric Reaming



Figure D
Trial Stem Placement



Figure E
Trial COR Guide &
Version Adjustment



Figure F
Neck & Head Trial
Assembly



Figure G
Version Guide



Figure H
Trial Extraction



Figure I
Final Stem Placement



Figure J
Final Stem Impaction

DETAILED OPERATIVE TECHNIQUE

APPROACH AND PATIENT POSITIONING

Selection of the surgical approach is dependent upon surgeon preference, the technical requirements of stem and/or cement removal, and femoral remodeling. The posterolateral approach is generally regarded as the “work horse” for revision surgery because of extensile capacity. Based on surgeon experience and prior incisions, an anterior supine or anterolateral approach might also be considered.

The use of an extended trochanteric osteotomy, trochanteric slide, and other advanced revision surgical techniques should be considered in some cases in which these techniques would facilitate stem and/or cement removal or improve correct access to the femoral canal (i.e. varus remodeling of the femur in which the greater trochanter limits access to the correct entry point for femoral reaming). An extended trochanteric osteotomy (ETO) is utilized for: (1) avoiding iatrogenic fracture/trochanteric escape (2) easing implant removal and (3) improving femoral exposure.

An assessment should be made of the pre-operative leg length discrepancy. This provides a point of reference to determine the change after hip reconstruction. In the lateral position, placing the knees and heels together can give the surgeon a general idea. With the anterior approach, fluoroscopy can be utilized.

SURGICAL TIP

We have found it helpful to confirm our surgical goal by making a pre-operative assessment regarding leg length discrepancies and then reviewing the pre-operative surgical plan to restore leg length and hip offset.

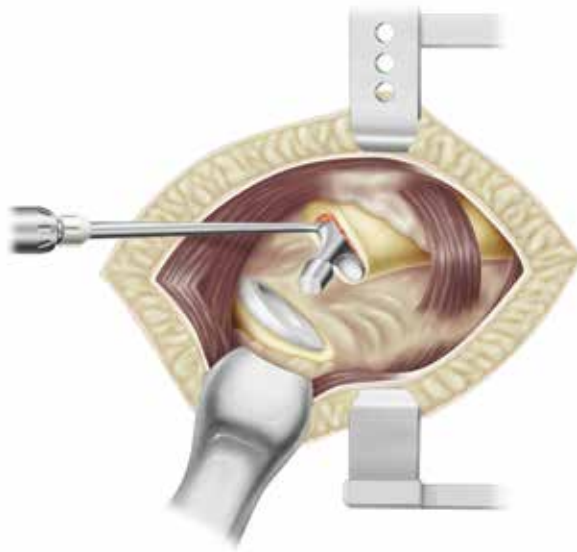

Figure 17
Femoral Component Removal

COMPONENT REMOVAL

Femoral reconstruction may be altered by the acetabular bone loss which may affect the planned COR of the hip. Should the acetabulum need to be revised, refer to the appropriate acetabular technique. Any movement of the acetabular COR which results from the revision should be compensated for by adjusting the planned COR or head offset choice, and associated measurements, recorded in the pre-operative plan.

Remove the existing femoral component and cement, if present (*Figure 17*).

The key surgical steps specific to stem and cement removal are beyond the scope of this operative technique.

SURGICAL TIP

The AcuDriver® Automated Osteotome System may be used to aid in removal of the primary femoral component. The AcuDriver System consists of an air-driven impact hand piece, a wide variety of osteotome attachments and a fiber optic illuminator that enhances visualization in the femoral canal. For key surgical steps specific to the AcuDriver, refer to the AcuDriver Operative Technique (*Figures 17 and 18*).

DETAILED OPERATIVE TECHNIQUE

OPENING OF THE FEMORAL CANAL (IF NECESSARY)



Figure 18
AcuDriver® Automated
Osteotome Assembly



Figure 19
Relief of Trochanteric Overhang

OPENING OF THE FEMORAL CANAL (IF NECESSARY)

The correct axial entrance point for femoral reaming can be estimated with templating on the pre-operative radiographs. In some cases, this requires relief of any trochanteric overhang to allow for a sufficiently lateral entry point which aids in avoiding varus reaming (*Figure 19*). In more extreme cases where the femur has remodeled into varus, the trochanter should be removed (extended trochanteric osteotomy) to allow access to the correct entry point for reaming.

If a bony pedestal has formed distally, it may need to be cautiously perforated with hand or power instruments. This may require intra-operative imaging.

SURGICAL TIP

The instrument set includes **Canal Entry Tools** and a **Starter Reamer** that may be used to gain access to the femoral canal.

Note: The **Modular Canal Entry Tools** are assembled with the **Modular Handle** prior to use. Ensure these tools properly lock into the Modular Handle.

DETAILED OPERATIVE TECHNIQUE

FEMORAL CANAL PREPARATION

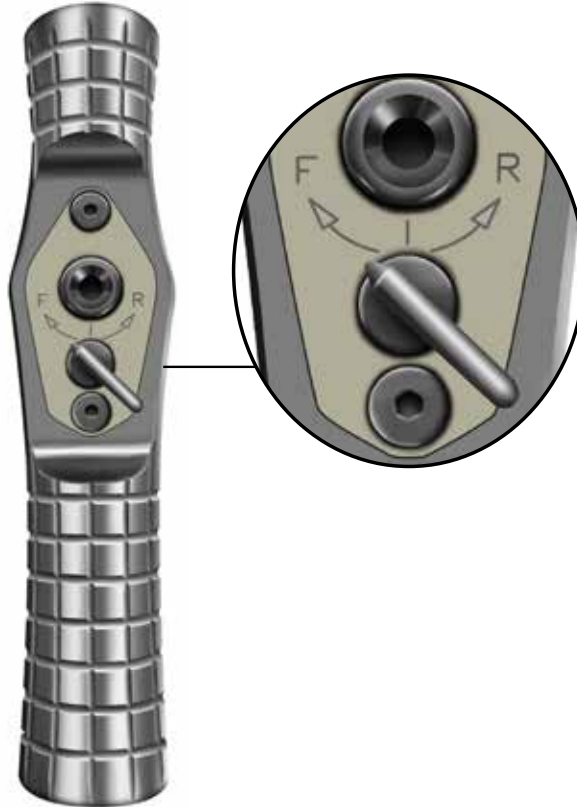

Figure 20
Ratcheting T-Handle

FEMORAL CANAL PREPARATION

Tapered Reaming

If there are areas of significant cortical damage, the surgeon may consider placing prophylactic cerclage wires or cables in the distal metaphysis or proximal diaphysis to minimize the risk of iatrogenic fracture during reamer or stem insertion.

In selected cases (patients with dense cortical bone), reaming under power may be beneficial. In either case however, the reaming process should be started by hand to minimize the risk of perforation of the cortex and to help establish the correct axial alignment for reaming and stem insertion.

Select a **Tapered Reamer** at least two diameters smaller than the templated stem. It is safer to start with smaller reamers

until the correct axial alignment has been established. Assemble the **Ratcheting T-Handle** to the Tapered Reamer. Check for full engagement of the mating features. Adjust the switch on the top of the handle to lock the ratchet in the desired mode (i.e. forward, reverse or locked) for hand reaming of the distal femoral canal (*Figure 20*).

SURGICAL TIP

Starting at least 2mm smaller helps the surgeon to better obtain the correct axial alignment prior to reaming with the final size reamer.



Figure 21
Cortical Bone Removal

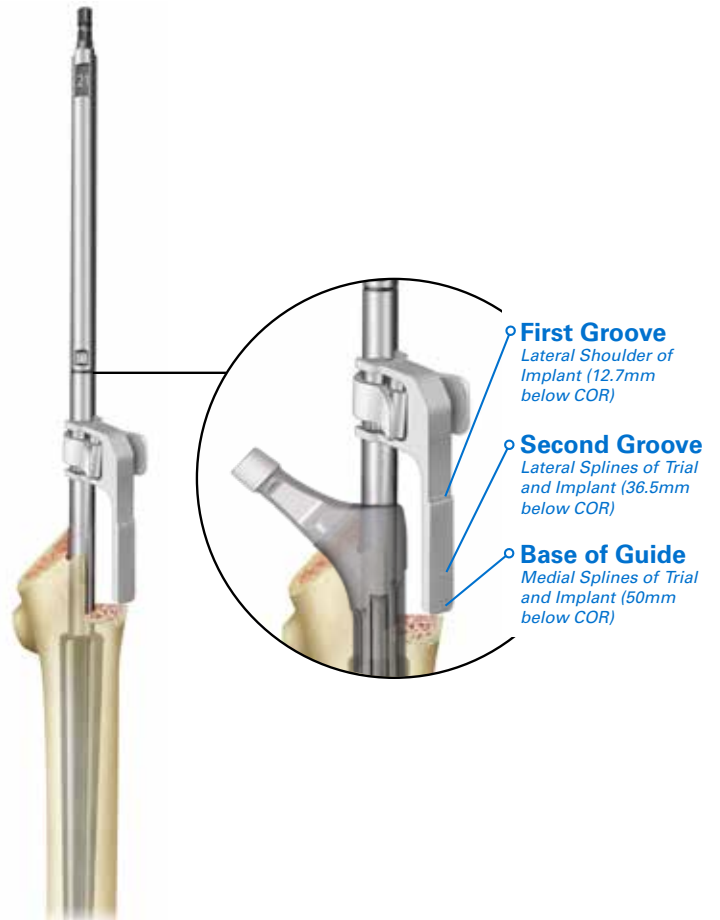

Figure 22
Tapered Reamer Referencing Guide

In addition to axial force during distal reaming, take care to guide the reamer tangentially such that it remains axial during reaming of the femoral bow.

Utilizing the preferred femoral reaming philosophy (Femoral Reaming Philosophies on page 5), continue progressively reaming until adequate axial and rotational stability are achieved at the desired COR and/or corresponding landmarks. In addition, inspecting the reamer should reveal 4cm or more of cortical bone that is being removed (*Figure 21*). As necessary, the Tapered Reamer Referencing Guide may be snapped onto the Tapered Reamer and used to mark the femur at locations distal to the COR that will correspond to features of the stem trial and final prosthesis (*Figure 22*).

The use of intra-operative radiography may be helpful in some cases. This is particularly true if there is a significant discrepancy between the templated stem size and the stem size suggested by reaming. Confirm on the lateral image that the tip of the reamer has not perforated distally.

DETAILED OPERATIVE TECHNIQUE

FEMORAL CANAL PREPARATION



Figure 23
Trochanteric Reaming



Figure 24
Trochanteric Reamer
Stop Window

Trochanteric Reaming

Trochanteric reaming is recommended in all cases to ensure the distal taper cavity is coaxial with the proximal cylindrical cavity. Performing this step helps to avoid three-point fixation of the stem instead of distal taper fixation, and will help to maintain the reproducibility of the system. After tapered reaming is complete, leave the final Tapered Reamer in the femoral canal.

Select the **Trochanteric Reamer** which matches the diameter of the final Tapered Reamer used. Connect the Trochanteric Reamer to power and slide the construct over the proximal reamer shaft (*Figure 23*). Start the Trochanteric Reamer prior to contacting the bone and then advance the Trochanteric Reamer distally until a hard stop is encountered. This stop

is the proximal end of the Tapered Reamer and should be confirmed by checking the window in the shaft (*Figure 24*).

It may be necessary to reorient the Trochanteric Reamer relative to the distal reamer shaft to ensure that it fully advances to the distal stop (confirmed in the window).

SURGICAL TIP

In order to minimize deflection of the greater trochanter, it is recommended to trochanteric ream with the Trochanteric Reamer diameter corresponding to the diameter of the final Tapered Reamer used.



Figure 25
Trial Stem Placement

Note: The size 14mm-16mm Trochanteric Reamers are a one-piece construct. The size 17mm-30mm Trochanteric Reamers are designed to be used with **Trochanteric Reamer Driver**, Size 17mm-30mm. The size 17mm-30mm Trochanteric Reamers are designed to stay assembled to the Trochanteric Reamer Driver when rotated clockwise. Do not run the Trochanteric Reamer Assembly in the reverse direction. If the Trochanteric Reamer becomes disassembled from the Trochanteric Reamer Driver, the Tapered Reamer flutes will act as a stop. Removing the Tapered Reamer will also remove the detached Trochanteric Reamer.

STEM TRIAL INSERTION

Remove the Tapered Reamer and Trochanteric Reamer (if applicable) from the femur.

Assemble the **Straight** or **Threaded Modular Stem Inserter** to the **Modular Handle**. Place the **Stem Trial** corresponding to the size of the final Tapered Reamer into the femoral cavity. Impact the Stem Trial until seated. Impaction of tapered stems is a “tap tap” process and rarely requires substantial blows with the mallet.

Once the taper of the stem engages the endosteal taper created by the Tapered Reamer, the stem will no longer advance axially and the tone created with each impact will change. When this occurs, the surgeon should not continue to impact the stem (*Figure 25*).

As the Stem Trial is being impacted confirm the proximal/medial portion of the Stem Trial does not contact the medial calcar as this can provide a false sense of stability.

DETAILED OPERATIVE TECHNIQUE

STEM TRIAL INSERTION



Figure 26
Trial COR Guide & Version Adjustment

The Stem Trial is designed so that it typically seats with the COR aligned to Tapered Reamer COR groove. Two situations may occur. First, if the Trial COR is more proximal than expected, three-point proximal fixation may be occurring or the medial aspect of the Stem Trial may be contacting the femur. In these situations it is recommended that the surgeon identify and remove any interfering bone. Second, in cases of severe bone loss, the Trial may seat more distally than expected, and the Trial reduction should be performed anticipating that the final femoral stem will seat with a feel consistent to the Trial.

SURGICAL TIP

If desired, the landmarks made using the Tapered Reamer Referencing Guide may be compared to the respective Stem Trial feature.

SURGICAL TIP

The **Trial Center of Rotation Guide** may be installed into the Stem Trial and used to provide visualization of the COR during the impaction of the Stem Trial (*Figure 26*). The Trial Center of Rotation Guide may also be used to rotate the Stem Trial into the desired anteversion.

Note: Lift lever to disengage the Trial Center of Rotation Guide.



Figure 27
Neck & Head Trial Assembly

Remove the Trial Center of Rotation Guide (if applicable) and install the appropriate **Neck Trial** into the Stem Trial.

SURGICAL TIP

The Neck Trials are grouped by the following sizes: 14-15, 16-20, 21-24, 26-30, and provide a unique coupling feature to ensure the appropriate Neck Trial is installed into the Stem Trial.

TRIAL REDUCTION

Select an appropriate **Head Trial** and assemble it onto the Stem and Neck Trial Assembly for trial reduction (*Figure 27*). It is generally preferable to begin the trialing process with the shortest femoral head to assess the leg length and minimize

the difficulties of reducing the stem. Longer offset heads can then be used to optimize leg length, if needed.

SURGICAL TIP

Should the shortest modular Head Trial (-3.5mm) be selected as the final construct, it is recommended that the surgeon advance the Tapered Reamer 2-3mm deeper into the femur. Advancing the Tapered Reamer deeper axially will allow the COR of the reduced trial construct to be recreated by (1) the Stem Trial with a +0mm Femoral Head and (2) the final implant with a -3.5mm Femoral Head.

DETAILED OPERATIVE TECHNIQUE

TRIAL REDUCTION



Figure 28
Version Guide

Once the optimal anteversion of the Stem Trial has been determined, it is helpful to mark this on the calcar (or proximal medial femur) to help reproduce this anteversion when inserting the final implant. The **Version Guide** is provided to allow the surgeon to mark the version of the final trial position on the femur and compare the orientation of the final prosthesis (*Figure 28*).



Figure 29
Trial Extraction



Figure 30
Final Stem Placement
(Using Trunion Version Guide)

TRIAL COMPONENT REMOVAL

Determine the final components for implantation. Dislocate the hip, and remove the Trial components. The **Stem Trial Extractor** may be used to extract the Stem Trial and is designed to be coupled to the **Slap Hammer** (Figure 29).

FINAL FEMORAL STEM PLACEMENT

Final Stem Insertion

Select the appropriate stem and place it in the prepared femur. The Version Guide can be placed on the trunion of the stem to aid in recreating the version alignment of the trial (Figure 30).

Measurements may be made off the Version Guide to ensure correct rotational alignment, version and depth of the stem. Using the desired Stem Inserter, impact the stem using a “tap tap” process. Forceful blows with the mallet are rarely indicated.

DETAILED OPERATIVE TECHNIQUE

FINAL FEMORAL STEM PLACEMENT



Figure 31
Final Stem Impaction

Once the stem stops advancing axially with mild blows, the tone created with each impact will change indicating no further impaction is needed (*Figure 31*). The stem should advance to approximately the same level as the trial implant. If desired, the landmarks made using the Tapered Reamer Referencing Guide may be compared to the location of each respective stem feature.

Another trial reduction can be performed with the final stem and Femoral Head Trial.

SURGICAL TIP

The stem is designed such that it will seat 2 to 4mm proud of the trial stem COR. The final seating height is multi-factorial, but is highly dependent on the quality of the bone. For poorer bone, the preparation technique and trialing will provide tactile guidance on whether the surgeon should plan for an atypical (or more distal) stem seating height.



Femoral Head Impaction

Clean and dry the taper of the femoral stem. Place the selected **Femoral Head Component** onto the taper of the Femoral Stem and secure it using the **Modular Femoral Head Impactor**. Ceramic Heads should be placed by hand with no direct impact with a mallet.

***Note:** If an ETO was performed, the osteotomy shall be repaired according to the preferred method.*

FINAL REDUCTION

Reduce the hip and perform a final check of length, range of motion and stability.

 **SURGICAL TIP**

At this point, the reconstructed leg length can be compared to the pre-operative assessment that was performed as the patient was being positioned.

Implant Removal

If it is necessary to intra-operatively remove the stem, the **Femoral Stem Extractor** may be assembled to the Slap Hammer to facilitate removal.

CLOSURE

Close the wound according to the preferred method.

SYSTEM SPECIFICATIONS

+0mm Femoral Head Offset & Length

A Size/Diameter (mm)	B Neck Height (mm)	C Lateral Offset (mm)	D Neck Length (mm)	E COR to Tip Length (mm)
14	27.3	40	36.8	195 & 245
15				
16-20	27.4			
21-24	29.0			
26-30	30.6	45	40.6	195 ,245

+0mm Femoral Head Landmark Measurements

E COR to Tip Length (mm)	F Taper Start Point (mm)	G COR to Lateral Shoulder (mm)	H COR to Medial Spline (mm)	J COR to Lateral Spline (mm)
195	75	12.7	50	36.5
245	125			
295	175			

Femoral Head Offset & Length Differences

Head Offset (mm)	ΔB Neck Height (Leg Length) (mm)	ΔC Lateral Offset (mm)	ΔD Neck Length (mm)
-3.5	-2.3	-2.7	-3.5
All differences measured from a +0mm Femoral Head			
+3.5	2.3	2.6	3.5
+7	4.6	5.3	7.0
+10	6.6	7.5	10.0

Distal Diameter

A Stem Size/Diameter (mm)	K Distal Diameter (mm)
14	6
15	7
16	8
17	9
18	10
19	11
20	12
21	13
22	14
23	15
24	16
26	18
28	20
30	22

IMPLANT ORDERING INFORMATION

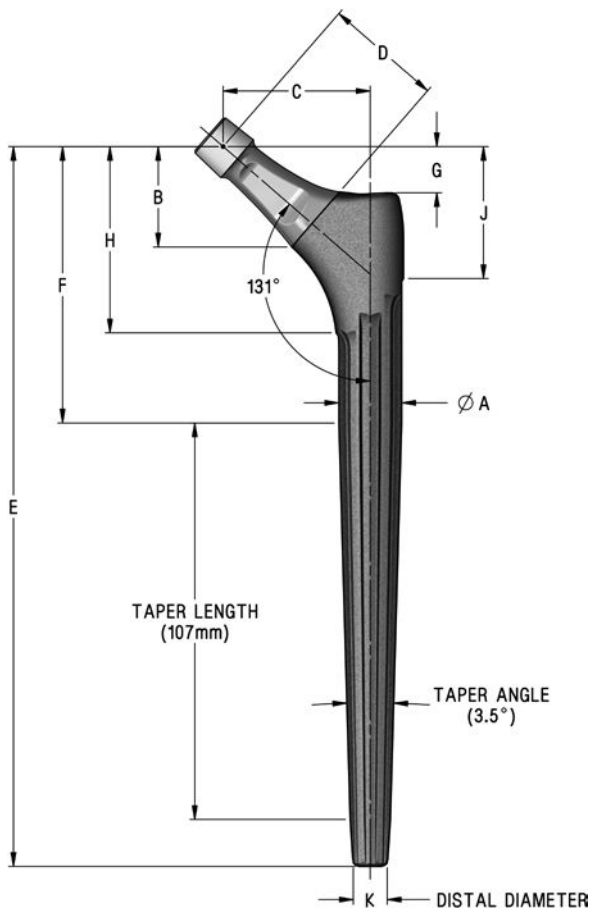

A Stem Size/ Diameter (mm)	E Length COR to Tip		
	195mm	245mm	295mm
14	01-010-14-4195	01-010-14-4245	
15	01-010-15-4195	01-010-15-4245	
16	01-010-16-4195	01-010-16-4245	01-010-16-4295
17	01-010-17-4195	01-010-17-4245	01-010-17-4295
18	01-010-18-4195	01-010-18-4245	01-010-18-4295
19	01-010-19-4195	01-010-19-4245	01-010-19-4295
20	01-010-20-4195	01-010-20-4245	01-010-20-4295
21	01-010-21-4195	01-010-21-4245	01-010-21-4295
22	01-010-22-4195	01-010-22-4245	01-010-22-4295
23	01-010-23-4195	01-010-23-4245	01-010-23-4295
24	01-010-24-4195	01-010-24-4245	01-010-24-4295
26	01-010-26-5195	01-010-26-5245	
28	01-010-28-5195	01-010-28-5245	
30	01-010-30-5195	01-010-30-5245	

INDICATIONS FOR USE

INDICATIONS FOR USE

All Exactech Hip Systems are indicated for use in skeletally mature individuals undergoing primary surgery for hip replacement due to osteoarthritis, rheumatoid arthritis, osteonecrosis, post-traumatic degenerative problems of the hip, and for treatment of proximal femoral fractures where prosthetic replacement is determined by the surgeon as the preferred treatment. Components of Exactech Hip Systems are also potentially indicated for ankylosing spondylitis, congenital hip dysplasia, revision of failed previous reconstructions where sufficient bone stock is present, and to restore mobility resulting from previous fusion.

- Cemented femoral stems and cemented acetabular cups are intended for cemented fixation only.
- Press-fit femoral stems and acetabular cups are intended for press-fit fixation.
- Femoral heads and endoprotheses are intended for use in cemented and press-fit applications.

OPT-1401 optional kit is available for sizes 26, 28 and 30mm.

OPT-1403 optional kit is available for 295mm length trials.

CONTRAINDICATIONS FOR USE

Use of the Exactech Hip Systems is contraindicated in the following situations:

- Patients with suspected or confirmed systemic infection or a secondary remote infection.
- Patients with inadequate or malformed bone that precludes adequate insertion or fixation of the prosthesis.
- Patients with neuromuscular disorders that do not allow control of the joint.
- The unipolar and bipolar endoprotheses are also contraindicated for use in patients with evidence of degenerative changes in the acetabulum and/or pelvic fractures.
- Patient's age, weight, or activity level would cause the surgeon to expect early failure of the system.

TRAY LAYOUT

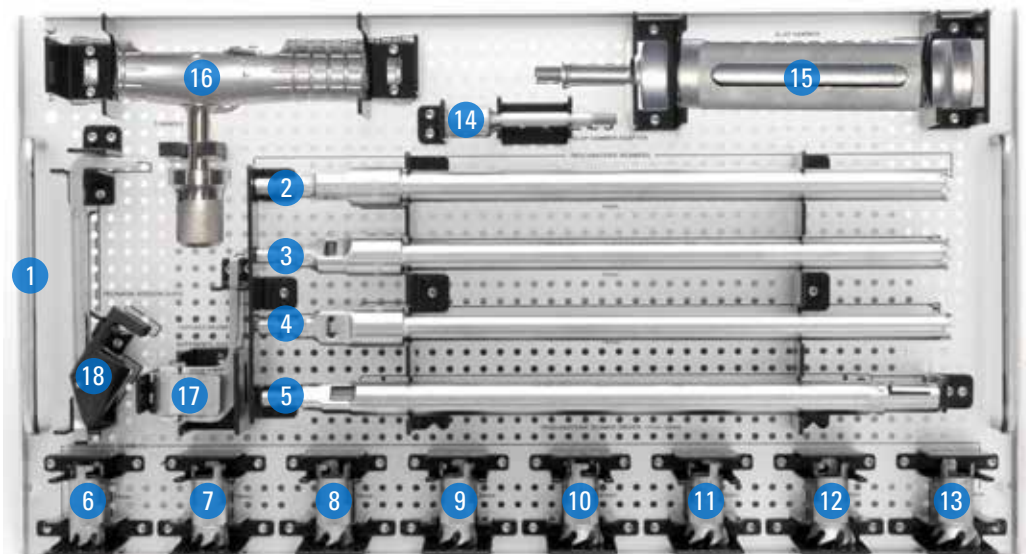

KIT-1401 Alteon Monobloc Reamer Kit (Upper Level Tray)

Site	Item	Item Description
Not Pictured	10-301-00-0001	Instrument Outer Case, Lid
1	01-019-04-0004	Instrument Tray, Reamer, Upper
2	01-019-01-1014	Monobloc Trochanteric Reamer, 14mm Diameter
3	01-019-01-1015	Monobloc Trochanteric Reamer, 15mm Diameter
4	01-019-01-1016	Monobloc Trochanteric Reamer, 16mm Diameter
5	01-019-01-1001	Monobloc Trochanteric Reamer Driver, Size 17-30mm
6	01-019-01-1017	Monobloc Trochanteric Reamer, 17mm Diameter
7	01-019-01-1018	Monobloc Trochanteric Reamer, 18mm Diameter
8	01-019-01-1019	Monobloc Trochanteric Reamer, 19mm Diameter
9	01-019-01-1020	Monobloc Trochanteric Reamer, 20mm Diameter
10	01-019-01-1021	Monobloc Trochanteric Reamer, 21mm Diameter
11	01-019-01-1022	Monobloc Trochanteric Reamer, 22mm Diameter
12	01-019-01-1023	Monobloc Trochanteric Reamer, 23mm Diameter
13	01-019-01-1024	Monobloc Trochanteric Reamer, 24mm Diameter
14	161-00-06	Femoral Stem Extractor
15	213-46-00	Slap Hammer
16	01-019-00-0000	Ratcheting T-Handle
17	01-019-01-0001	Tapered Reamer Referencing Guide
18	01-019-03-0000	Trunnion Version Guide

OPT-1401 optional kit is available for sizes 26, 28 and 30mm.

OPT-1403 optional kit is available for 295mm length trials.

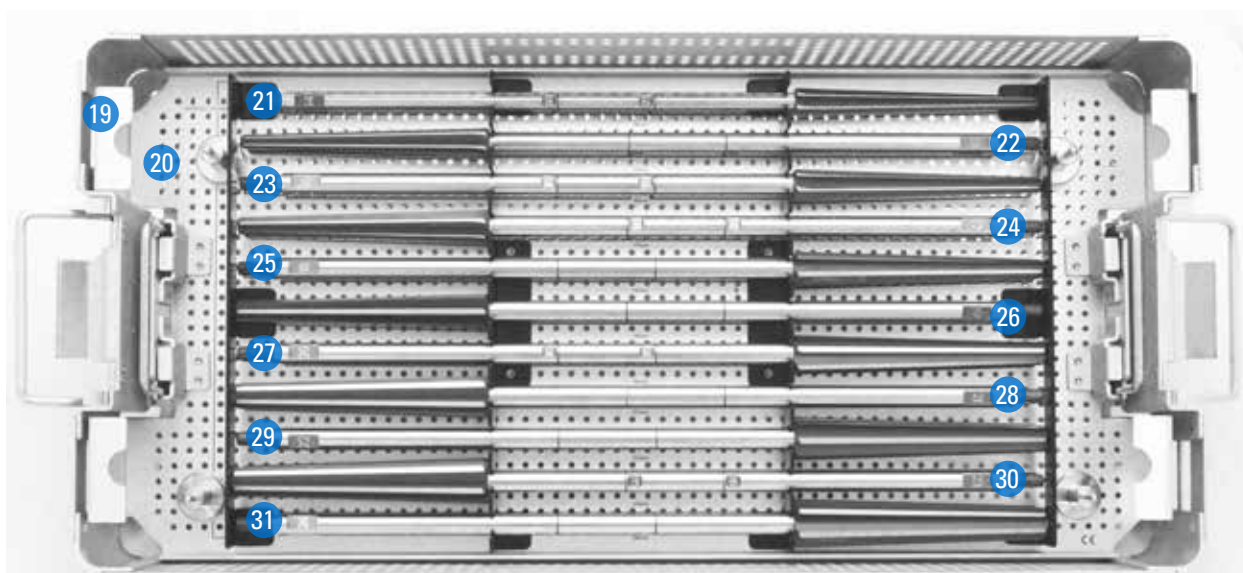

KIT-1401 Alteon Monobloc Reamer Kit (Lower Level Tray)

Site	Item	Item Description
19	10-111-00-0001	Instrument Outer Case, Single-Level
20	01-019-04-0003	Instrument Tray, Reamer, Lower
Not Pictured	161-06-00	Lateralizing Reamer
Not Pictured	01-019-01-0012	Monobloc Tapered Reamer, 12mm Diameter
Not Pictured	01-019-01-0013	Monobloc Tapered Reamer, 13mm Diameter
21	01-019-01-0014	Monobloc Tapered Reamer, 14mm Diameter
22	01-019-01-0015	Monobloc Tapered Reamer, 15mm Diameter
23	01-019-01-0016	Monobloc Tapered Reamer, 16mm Diameter
24	01-019-01-0017	Monobloc Tapered Reamer, 17mm Diameter
25	01-019-01-0018	Monobloc Tapered Reamer, 18mm Diameter
26	01-019-01-0019	Monobloc Tapered Reamer, 19mm Diameter
27	01-019-01-0020	Monobloc Tapered Reamer, 20mm Diameter
28	01-019-01-0021	Monobloc Tapered Reamer, 21mm Diameter
29	01-019-01-0022	Monobloc Tapered Reamer, 22mm Diameter
30	01-019-01-0023	Monobloc Tapered Reamer, 23mm Diameter
31	01-019-01-0024	Monobloc Tapered Reamer, 24mm Diameter

OPT-1401 optional kit is available for sizes 26, 28 and 30mm.

OPT-1403 optional kit is available for 295mm length trials.

TRAY LAYOUT

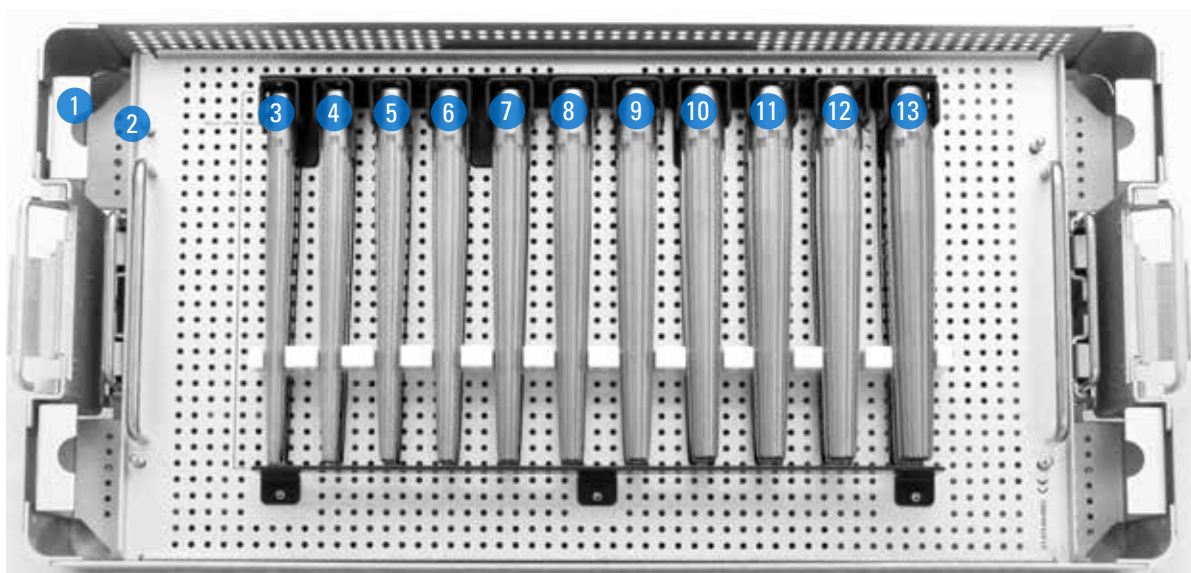

KIT-1403 Alteon Monobloc Trial Kit (Upper Level Tray)

Site	Item	Item Description
Not Pictured	10-301-00-0001	Instrument Outer Case, Lid
1	10-111-00-0001	Instrument Outer Case, Single-Level
2	01-019-04-0002	Instrument Tray, Trial, Upper
3	01-011-14-2195	Monobloc Stem Trial, 14mm Diameter x 195mm Long
4	01-011-15-2195	Monobloc Stem Trial, 15mm Diameter x 195mm Long
5	01-011-16-2195	Monobloc Stem Trial, 16mm Diameter x 195mm Long
6	01-011-17-2195	Monobloc Stem Trial, 17mm Diameter x 195mm Long
7	01-011-18-2195	Monobloc Stem Trial, 18mm Diameter x 195mm Long
8	01-011-19-2195	Monobloc Stem Trial, 19mm Diameter x 195mm Long
9	01-011-20-2195	Monobloc Stem Trial, 20mm Diameter x 195mm Long
10	01-011-21-2195	Monobloc Stem Trial, 21mm Diameter x 195mm Long
11	01-011-22-2195	Monobloc Stem Trial, 22mm Diameter x 195mm Long
12	01-011-23-2195	Monobloc Stem Trial, 23mm Diameter x 195mm Long
13	01-011-24-2195	Monobloc Stem Trial, 24mm Diameter x 195mm Long

OPT-1401 optional kit is available for sizes 26, 28 and 30mm.

OPT-1403 optional kit is available for 295mm length trials.

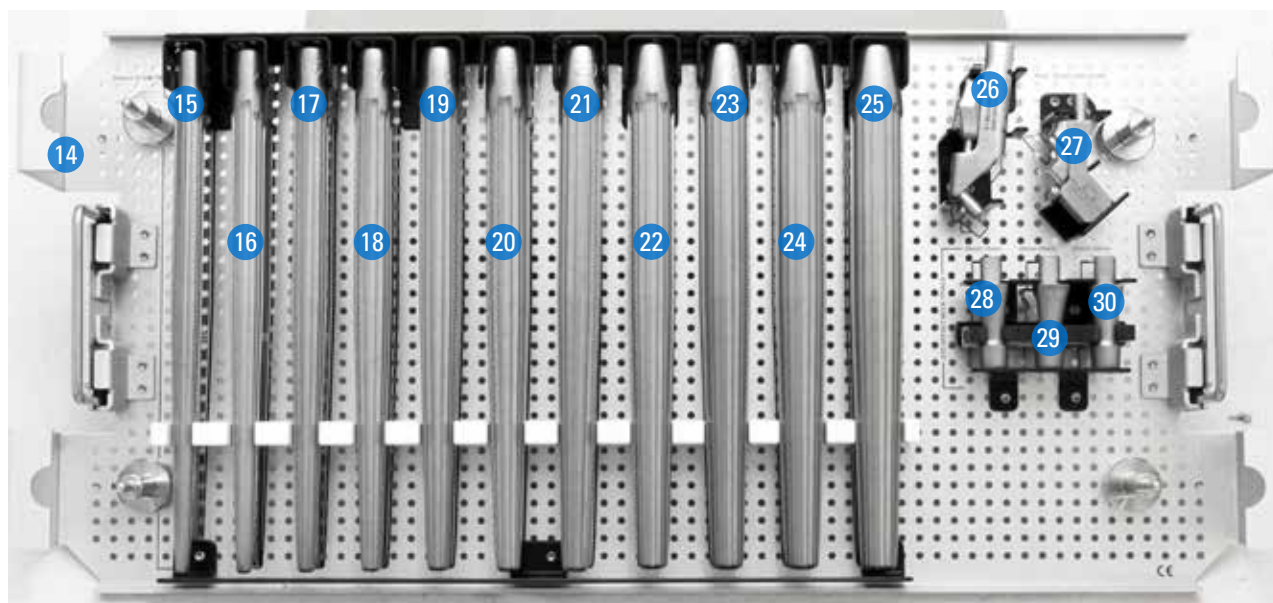

KIT-1403 Alteon Monobloc Trial Kit (Lower Level Tray)

Site	Item	Item Description
14	01-019-04-0001	Instrument Tray, Trial, Lower
15	01-011-14-2245	Monobloc Stem Trial, 14mm Diameter x 245mm Long
16	01-011-15-2245	Monobloc Stem Trial, 15mm Diameter x 245mm Long
17	01-011-16-2245	Monobloc Stem Trial, 16mm Diameter x 245mm Long
18	01-011-17-2245	Monobloc Stem Trial, 17mm Diameter x 245mm Long
19	01-011-18-2245	Monobloc Stem Trial, 18mm Diameter x 245mm Long
20	01-011-19-2245	Monobloc Stem Trial, 19mm Diameter x 245mm Long
21	01-011-20-2245	Monobloc Stem Trial, 20mm Diameter x 245mm Long
22	01-011-21-2245	Monobloc Stem Trial, 21mm Diameter x 245mm Long
23	01-011-22-2245	Monobloc Stem Trial, 22mm Diameter x 245mm Long
24	01-011-23-2245	Monobloc Stem Trial, 23mm Diameter x 245mm Long
25	01-011-24-2245	Monobloc Stem Trial, 24mm Diameter x 245mm Long
26	01-019-02-0000	Femoral Stem Trial Extractor
27	01-011-02-0000	Trial Center of Rotation Guide
28	01-011-00-1415	Monobloc Neck Trial, Standard Offset, Size 14-15
29	01-011-00-1620	Monobloc Neck Trial, Standard Offset, Size 16-20
30	01-011-00-2124	Monobloc Neck Trial, Standard Offset, Size 21-24

OPT-1401 optional kit is available for sizes 26, 28 and 30mm.

OPT-1403 optional kit is available for 295mm length trials.

TRAY LAYOUT

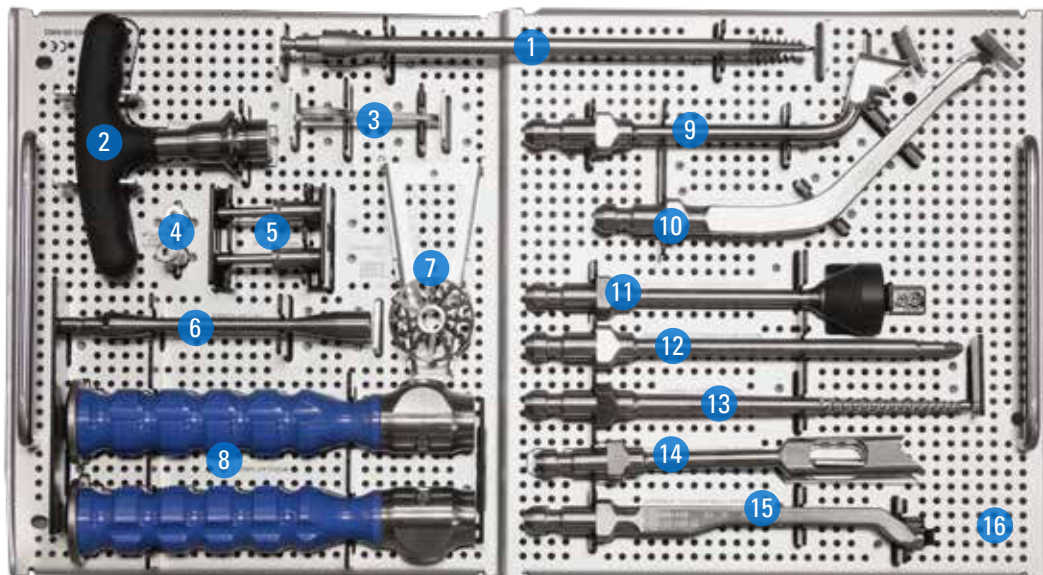

KIT-1003 Alteon Common Femoral Instruments (Upper Level Tray)

Site	Item	Item Description
Not Pictured	10-111-00-0001	Instrument Outer Case, Single-Level
Not Pictured	10-301-01-0001	Instrument Outer Case, Lid
1	167-00-01	Corkscrew, Sharp
2	301-07-70	Small T-Handle
3	01-003-04-0005	Calcar Planer Wrench
4	01-003-04-0004	Calcar Planer Bushing, Broach Hole Adaptor
5	01-003-04-0003	Calcar Planer Bushing, Broach Post Adaptor
6	01-003-04-0001	Calcar Planer Assembly, Shaft
7	01-003-04-0002	Calcar Planer Blade, 1.5"
8	01-001-00-0001	Modular Handle
9	01-001-05-0003	Modular Box Osteotome, Reduced Offset
10	01-001-01-0002	Modular Stem Inserter, Offset
11	01-001-03-0001	Modular Femoral Head Impactor
12	01-001-01-0003	Modular Stem Inserter, Threaded
13	01-001-06-0001	Modular Straight Canal Finder, Blunt
14	01-001-05-0001	Modular Box Osteotome, Straight
15	01-001-01-0001	Modular Stem Inserter, Straight
16	01-003-00-0002	Common Femoral Tray, Upper Inner Tray

OPT-1401 optional kit is available for sizes 26, 28 and 30mm.

OPT-1403 optional kit is available for 295mm length trials.

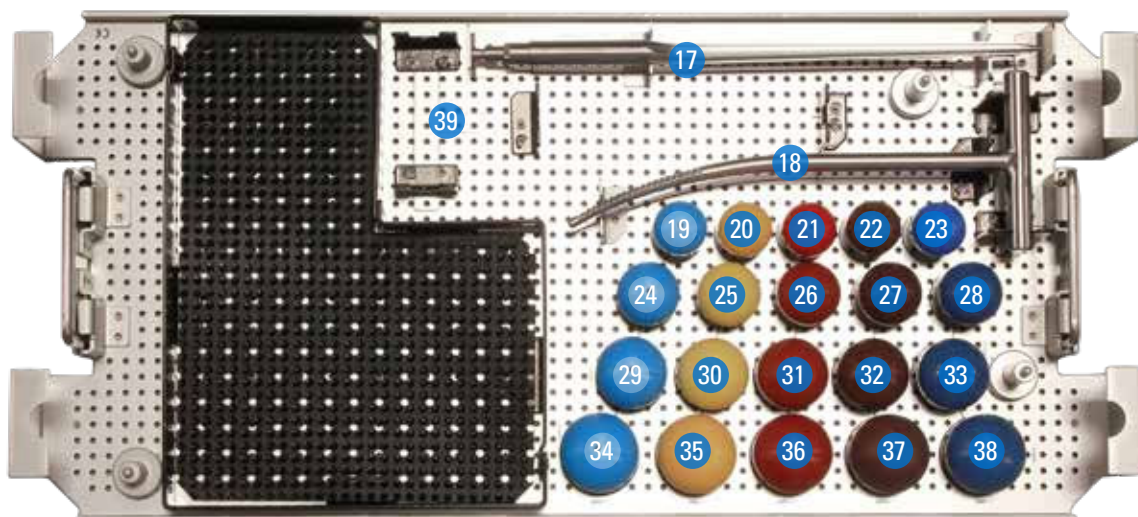

KIT-1003 Alteon Common Femoral Instruments (Lower Level Tray)

Site	Item	Item Description
17	01-003-07-0001	Starter Reamer
18	01-003-06-0003	Curved Canal Finder, Blunt
19	143-28-10	Femoral Head Trial, 28, +10mm, O-Ring, 12/14
20	143-28-07	Femoral Head Trial, 28, +7mm, O-Ring, 12/14
21	143-28-03	Femoral Head Trial, 28, +3.5mm, O-Ring, 12/14
22	143-28-00	Femoral Head Trial, 28, +0mm, O-Ring, 12/14
23	143-28-93	Femoral Head Trial, 28, -3.5mm, O-Ring, 12/14
24	143-32-10	Femoral Head Trial, 32, +10mm, O-Ring, 12/14
25	143-32-07	Femoral Head Trial, 32, +7mm, O-Ring, 12/14
26	143-32-03	Femoral Head Trial, 32, +3.5mm, O-Ring, 12/14
27	143-32-00	Femoral Head Trial, 32, +0mm, O-Ring, 12/14
28	143-32-93	Femoral Head Trial, 32, -3.5mm, O-Ring, 12/14
29	143-36-10	Femoral Head Trial, 36, +10mm, O-Ring, 12/14
30	143-36-07	Femoral Head Trial, 36, +7mm, O-Ring, 12/14
31	143-36-03	Femoral Head Trial, 36, +3.5mm, O-Ring, 12/14
32	143-36-00	Femoral Head Trial, 36, +0mm, O-Ring, 12/14
33	143-36-93	Femoral Head Trial, 36, -3.5mm, O-Ring, 12/14
34*	143-40-10	Femoral Head Trial, 40, +10mm, O-Ring, 12/14
35*	143-40-07	Femoral Head Trial, 40, +7mm, O-Ring, 12/14
36*	143-40-03	Femoral Head Trial, 40, +3.5mm, O-Ring, 12/14
37*	143-40-00	Femoral Head Trial, 40, +0mm, O-Ring, 12/14
38*	143-40-93	Femoral Head Trial, 40, -3.5mm, O-Ring, 12/14
39	01-003-00-0001	Common Femoral Tray, Lower Inner Tray

**Special Order Only.*

TRAY LAYOUT

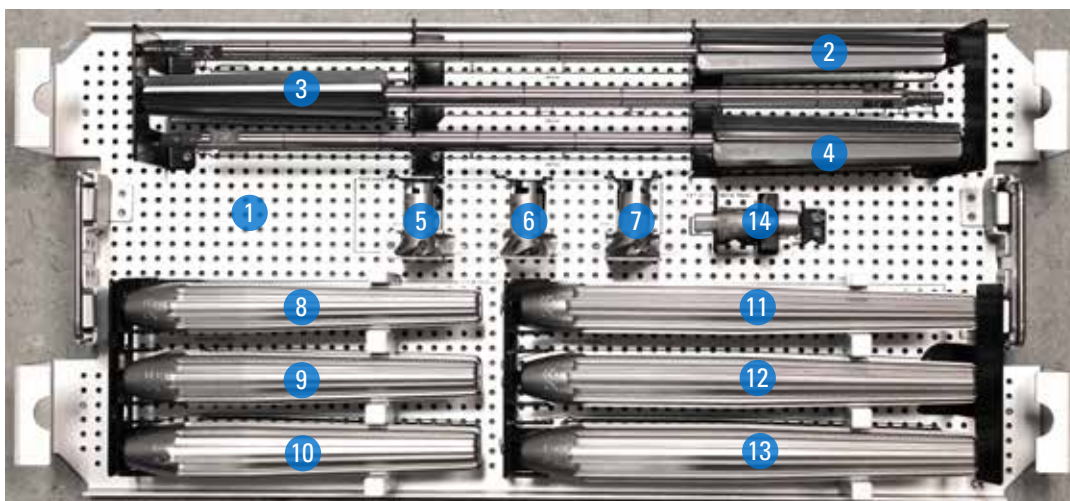

OPT-1401 Alteon Monobloc Macro Kit

Site	Item	Item Description
Not Pictured	10-301-00-0001	Instrument Outer Case, Lid
Not Pictured	10-111-00-0001	Instrument Outer Case, Single-Level
1	01-019-04-0005	Instrument Tray, Size 26-30
2	01-019-01-0026	Monobloc Tapered Reamer, 26mm Diameter
3	01-019-01-0028	Monobloc Tapered Reamer, 28mm Diameter
4	01-019-01-0030	Monobloc Tapered Reamer, 30mm Diameter
5	01-019-01-1026	Monobloc Trochanteric Reamer, 26mm Diameter
6	01-019-01-1028	Monobloc Trochanteric Reamer, 28mm Diameter
7	01-019-01-1030	Monobloc Trochanteric Reamer, 30mm Diameter
8	01-011-26-2195	Monobloc Stem Trial, 26 mm Diameter x 195mm Long
9	01-011-28-2195	Monobloc Stem Trial, 28 mm Diameter x 195mm Long
10	01-011-30-2195	Monobloc Stem Trial, 30 mm Diameter x 195mm Long
11	01-011-26-2245	Monobloc Stem Trial, 26 mm Diameter x 245mm Long
12	01-011-28-2245	Monobloc Stem Trial, 28 mm Diameter x 245mm Long
13	01-011-30-2245	Monobloc Stem Trial, 30 mm Diameter x 245mm Long
14	01-011-01-2630	Monobloc Neck Trial, Extended Offset, Size 26-30

OPT-1401 optional kit is available for sizes 26, 28 and 30mm.

OPT-1403 optional kit is available for 295mm length trials.

OPT-1403 Alteon Monobloc 295 Trial Kit

Item	Item Description
01-011-16-2295	Monobloc Stem Trial, 16mm Diameter x 295mm Long
01-011-17-2295	Monobloc Stem Trial, 17mm Diameter x 295mm Long
01-011-18-2295	Monobloc Stem Trial, 18mm Diameter x 295mm Long
01-011-19-2295	Monobloc Stem Trial, 19mm Diameter x 295mm Long
01-011-20-2295	Monobloc Stem Trial, 20mm Diameter x 295mm Long
01-011-21-2295	Monobloc Stem Trial, 21mm Diameter x 295mm Long
01-011-22-2295	Monobloc Stem Trial, 22mm Diameter x 295mm Long
01-011-23-2295	Monobloc Stem Trial, 23mm Diameter x 295mm Long
01-011-24-2295	Monobloc Stem Trial, 24mm Diameter x 295mm Long

OPT-1401 optional kit is available for sizes 26, 28 and 30mm.

OPT-1403 optional kit is available for 295mm length trials.

For additional device information, refer to the Exactech Hip System—Instructions for Use for a device description, indications, contraindications, precautions and warnings. For further product information, please contact Customer Service, Exactech, Inc., 2320 NW 66th Court, Gainesville, Florida 32653-1630, USA. (352) 377-1140, (800) 392-2832 or FAX (352) 378-2617.

Exactech, as the manufacturer of this device, does not practice medicine, and is not responsible for recommending the appropriate surgical technique for use on a particular patient. These guidelines are intended to be solely informational and each surgeon must evaluate the appropriateness of these guidelines based on his or her personal medical training and experience. Prior to use of this system, the surgeon should refer to the product package insert for comprehensive warnings, precautions, indications for use, contraindications and adverse effects.

The products discussed herein may be available under different trademarks in different countries. All copyrights, and pending and registered trademarks, are property of Exactech, Inc. This material is intended for the sole use and benefit of the Exactech sales force and physicians. It should not be redistributed, duplicated or disclosed without the express written consent of Exactech, Inc. ©2018 Exactech, Inc. 711-73-00 Rev. B 1118

Exactech is proud to have offices and distributors around the globe.
For more information about Exactech products available in your country, please visit www.exac.com



GLOBAL HEADQUARTERS
2320 NW 66TH COURT
GAINESVILLE, FL 32653 USA

☎ +1 352.377.1140

+1 800.EXACTECH

📠 +1 352.378.2617

🌐 www.exac.com