



Design is
Instrumental.

ALTEON[®]

Monobloc Revision Femoral Stem

Surgeon focused. Patient driven.[™] **Exactech**[®]



The Alteon® Monobloc Revision Femoral Stem is a press-fit, distally fixed, one-piece tapered, splined titanium stem. It incorporates specific philosophies designed to improve surgical experiences and clinical outcomes. The Monobloc Revision Femoral Stem intends to achieve axial and rotational mechanical stability and operative predictability through a carefully engineered combination of design features.

TAPER ANGLE AND SPLINE DESIGN

The 3.5 degree taper angle and flat/broad spline geometry play an integral part in the mechanical stability that is designed to resist axial subsidence and rotation.¹

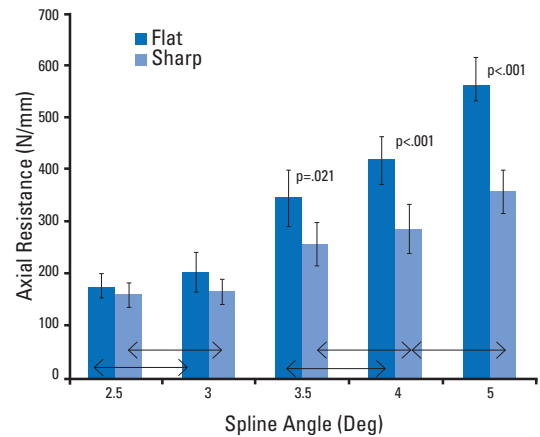
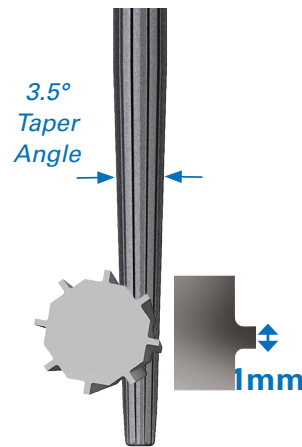

The chart above shows axial stability of different taper angles. The arrows indicate groups of statistically equivalent spline angles within each separate spline design.*

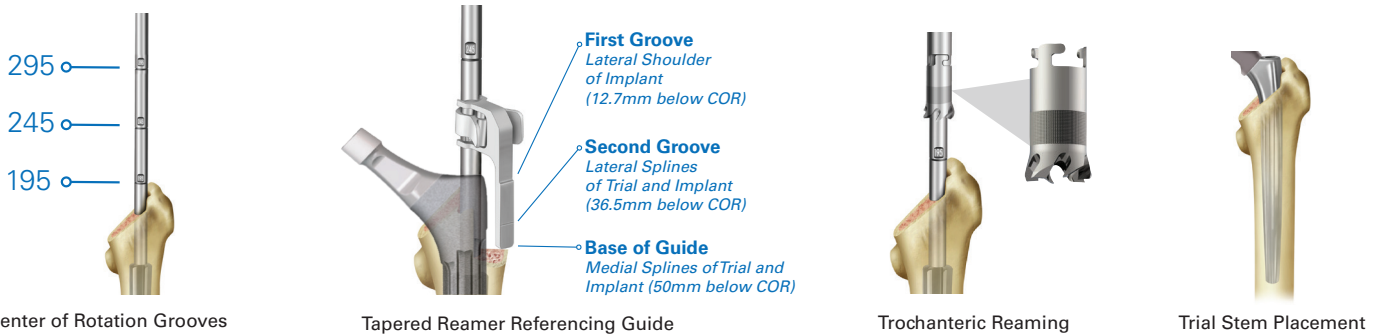

REAMER AND TRIAL-TO-IMPLANT RELATIONSHIP PREDICTABILITY

The surgical technique and instrumentation are designed to create a predictable relationship between the reamer, trial and implant locations. The result is a system with the potential for immediate and long-term center of rotation reliability and stability.

STREAMLINED INSTRUMENTATION

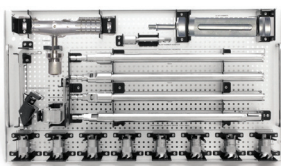

Alteon Monobloc Reamer Kit

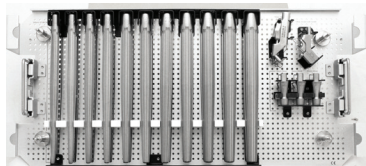

Alteon Monobloc Trial Kit

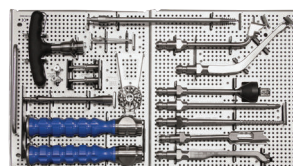

Alteon Common Femoral Kit

SCOPE

- Sizes/diameters: 14-24, 26, 28 and 30mm
- Lengths: 195, 245 & 295mm (Center of rotation to distal tip)

References

1. Pierson J, Small S, Rodriguez J, Kang M, Glassman A. The Effect of Taper Angle and Spline Geometry on the Initial Stability of Tapered, Splined Modular Titanium Stems. J Arthroplasty. 2015 Jul;30(7):1254-9.

*Laboratory test results may not necessarily be indicative of clinical performance.